

MOUNTING-KIT LIFT-OFF PREVENTION FOR MOD. 350

LASTECKE MIT ABHEBESICHERUNG FÜR MOD. 350

- Material:
 Alloy Steel zinc-plated Acc. **35902-35903**
 Stainless Steel Acc. **35902i-35903i**

- Material:
 Verzinkter Stahl: Zub. **35902-35903**
 Edelstahl: Zub. **35902i-35903i**

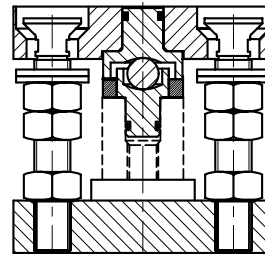
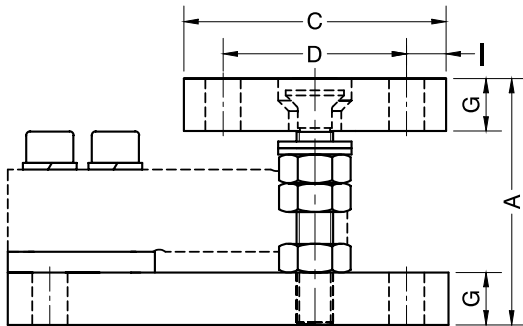

View from below / Ansicht von unten

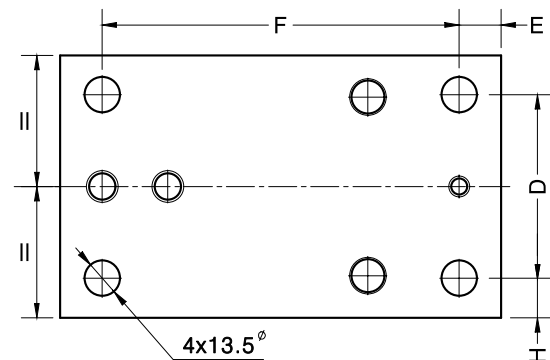
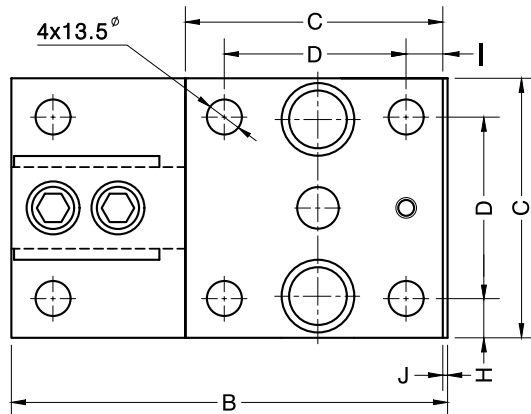

Accessory Zubehör	Nominal load Nennlast	A	B	C	D	E	F	G	H	I	J	Transport weight Transportgewicht
35902	0.3...2 t	94	168	100	70	16	136	20	15	15	1	5 kg
35903	3...5 t	113	212	120	84	18	175	25	18	18	-	8.5 kg

	Alloy Steel zinc-plated / Verzinkter Stahl		Stainless Steel / Edelstahl	
	35902	35903	35902i	35903i
Maximum permissible offset transverse to load cell <i>Max. Verschiebung in Querrichtung</i>	±2.5 mm	±2 mm	±2.5 mm	±2 mm
Maximum lift-off force <i>Max. Zugkraft vertical</i>	69 kN	113.04 kN	69 kN	113.04 kN
Maximum force horizontal to load cell <i>Max. Kraft in horizontale Richtung</i>	7.93 kN	11.8 kN	5 kN	11.8 kN

Dimensions in mm. Abmessungen in mm.